

# Eco/miser DISHWASHER

PROJECT NAME:

LOCATION:

ITEM #:

Qty:

MODEL #

**SU-01**



### FEATURES OF PROGRAMMABLE CONTROLLER

- ⦿ Maximizes washing efficiency and provides a clean environment
- ⦿ Minimum required wash and rinse temperatures
- ⦿ Built-in electric heater with a powerful rinse pump
- ⦿ Constant pressure and temperature
- ⦿ Pumped liquid detergent and rinse agent
- ⦿ Automatic pumped drain

### STANDARD FEATURES

- ⦿ Raises incoming water 140°F → 180°F hot water sanitizing
- ⦿ Variable time cycles (25~210 seconds)
- ⦿ Maximum rack capacity of 40 racks per hour
- ⦿ Automatic water fill, automatic start/stop
- ⦿ 3 factory preset options (40/36/30 racks per hour, 90/100/120 seconds per cycle): 70 seconds powerful wash, 10 seconds dwell time, 10 second hot water rinse.
- ⦿ Stainless steel non-clogging wash and rinse impeller
- ⦿ 304L stainless steel for corrosion resistance
- ⦿ Easily removable, large capacity, one-piece strainer
- ⦿ Solid state, integrated LED display controls with status indicators
- ⦿ Low-noise and large output 1 Hp washing pump
- ⦿ Unique design rotating high pressure rinse impellers, both upper and lower, rinse nozzles are easily removable and interchangeable for cleaning and inspection
- ⦿ Factory installed vacuum breaker
- ⦿ Door actuated start
- ⦿ Service diagnostics

### OPTIONS Included

15A (1/2") water inlet hose / 5feet (1.5 m)  
 Drain outlet hose / 4 feet (1.2m)

Pin Rack

QTY

2

Common Rack

1



Specifications subjected to change without notice.

APPROVALS: ETL

- Ⓢ-Electrical supply connection  
(208-230 VOLT / 220V/1Ph/17 amp)  
(Comes with 6ft(1.8m) cord for direct connection)
- W-Hot water connection  
(10psi~40psi(0.7kg/cm2~2.8kg/cm2)  
(Optimum water pressure/ 15psi(1.0kg/cm2)  
(Spray water hardness 5 Grains)  
(Connect to 3/4" male screw)
- D-Drain hose connection  
(MAX HEIGHT 18.0"(457mm)

Legend

Deep	Door open	41.5"(1,053mm)
	Door close	25.4"(647mm)
Electric	A	32.5"(827mm)
	a	2.0"(51mm)
Water	B	24.3"(618mm)
	b	15.6"(397mm)
Drain	C	32.5"(827mm)
	c	7.7"(195mm)

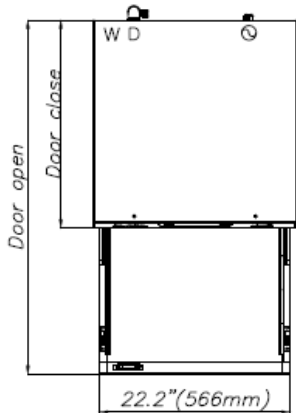

Top View

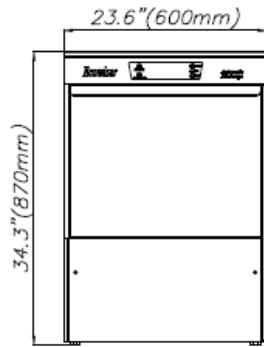

Front View

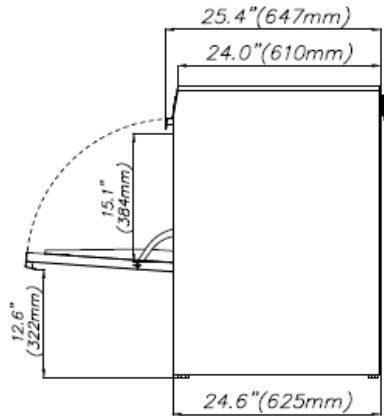

Side View

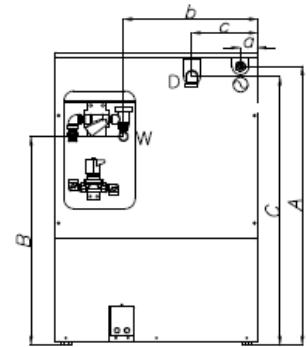

Rear View

Model	Capacity (Rack/H)	Cycle (sec)	Weight (lbs.)	W	D	H	Amp	Volts	Kw	Hz	PH	1 Cycle Water Consumption
SU-01	40	90	229	23.6	25.4	34.2	17	220	3.8	60	1	0.8gal (3.0L)

REMARK